

# GUN BOSS™ -AK47 – COMPACT CLEANING ROD KIT



The Gun Boss AK47 system cleans and protects AK47's with task specific high quality tools in a compact weather resistant case. Follow these simple steps when cleaning your rifle to ensure proper function and reliability.

## SAFETY FIRST

**BE SURE YOUR FIREARM IS UNLOADED: REMOVE THE MAGAZINE. PULL BACK ON THE CHARGING HANDLE, AND MAKE CERTAIN THAT THE CHAMBER IS EMPTY. WORK IN A WELL VENTILATED AREA AND WEAR EYE AND HAND PROTECTION.**

**NOTE:** It is important that when possible your cleaning strokes follow from action to muzzle. During cleaning it is also important that the barrel is angled so that excess solvent will exit the muzzle and not drain back into the action.

## AK47 CLEANING INSTRUCTIONS

**STEP 1:** A unique double-ended chamber brush allows you to clean the AK47's chamber and barrel trunnion from two different directions. If the rear of the gun obstructs the path of the rod then attach the front of the brush and rotate from the muzzle end of the gun (see images). Assemble the rod sections **WITHOUT** the rotating rod and attach the T-handle. Apply cleaning solvent to the chamber brush and rotate in the chamber. Take care not to insert the chamber brush all the way into the bore.

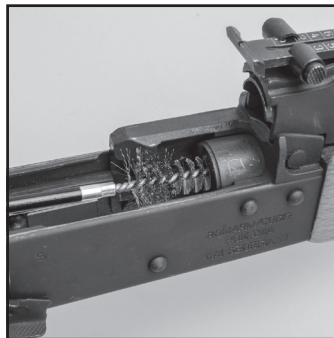

FROM REAR

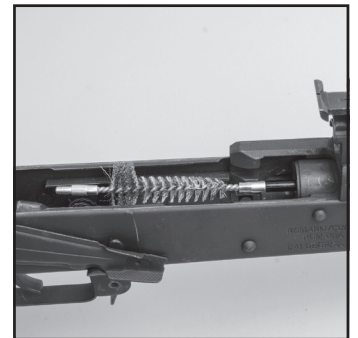

FROM FRONT

**STEP 2:** Locate the rotating rod section and connect it to the T-handle. Assemble the necessary length of rods and connect the slotted bore patch tip to the end. Slide a cleaning patch through the tip and apply a generous amount of cleaning solvent to the patch.



**STEP 3:** Carefully guide the slotted bore patch tip with the patch through the bore from action to muzzle. This step moistens and begins to loosen fouling.



**STEP 4:** Attach the bore brush to the rod. Guide the rod and push the brush through the bore from action to muzzle. This step loosens more fouling.

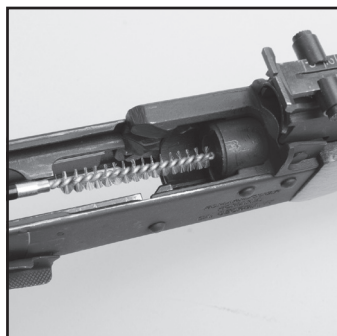

**STEP 5:** Re-attach the slotted bore patch tip to the rod with a clean & dry patch. Push the clean patch through the bore. The patch will absorb the loosened fouling. Repeat steps 3 – 5 using multiple patches until the patch comes out clean.



# GUN BOSS™ -AK47 – COMPACT CLEANING ROD KIT

## CLEANING INSTRUCTIONS CONTINUED

**STEP 6:** Remove the gas tube using the AK47 piston carbon scraper tool included in the kit. The gas tube is typically one of the dirtiest parts of an AK47, along with the gas piston that travels inside the tube. These two parts should be coated with a generous coating of cleaning solvent and set aside for several minutes to soak – loosening the carbon.

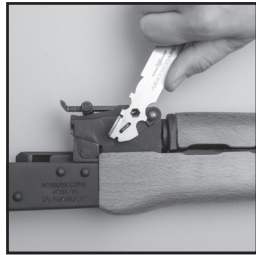

**STEP 8:** Remove the gas tube brush from the rod and replace it with the gas tube mop (dry). Run the gas tube mop through the gas tube several times to remove any remaining cleaning solvent.



**STEP 7:** Attach the large round nylon brush to two rod sections (non-rotating) and attach the T-handle. Apply cleaning solvent to the gas tube brush and rotate inside the gas tube. Wrap a clean patch around the gas tube brush and run it through the gas tube to remove the carbon. Repeat this several times until the patch comes out clean.



**STEP 9:** Use the pin punch as a reamer to clean the opening of the gas port above the barrel.

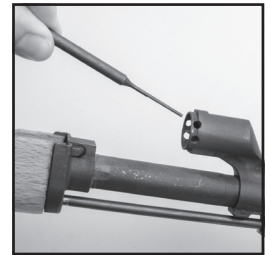

**STEP 10:** The gas piston and firing pin need to be cleaned and scraped thoroughly to keep your AK47 operating efficiently. The Real Avid AK47 scraper tool is designed to remove carbon from all of the key points that collect carbon.

Use the pin punch to remove the firing pin retaining pin from the bolt. Then remove the firing pin. Use the scraper to clean the tip of the firing pin. Re-assemble the firing pin into the bolt. [Note: Cleaning the firing pin is not required every time you shoot. This cleaning step is only needed occasionally.]

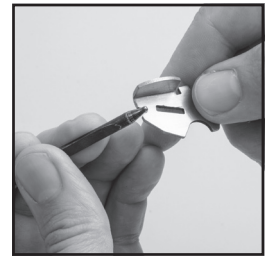
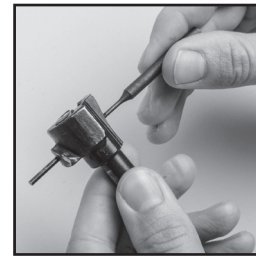

**STEP 11:** Scrape the gas piston thoroughly using the scraper. Because of the large number of AK47 variants the scraper tool is designed with three different shapes to clean the face of the piston. These profiles will remove the baked-on carbon from the concave piston face.

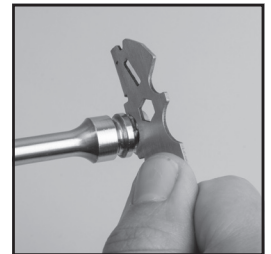
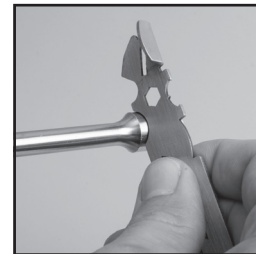
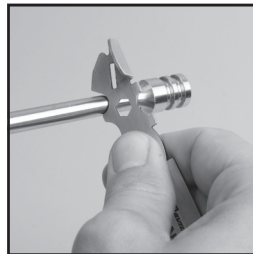

**STEP 12:** If required – use the nylon shaped brush to remove any dirt from the action of the AK47. Use a clean and dry rag to wipe any excess cleaning solvent from the AK47 parts. Apply gun oil to the critical friction points of the slide rails and bolt, then reassemble the gun.

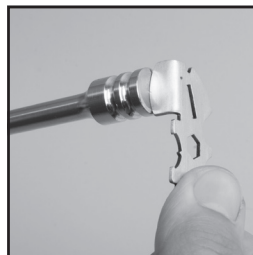

**NOTE:** After handling a firearm it is good practice to wipe down external metal components with a very light coat of CLP or gun oil to reduce oxidation.

**TO FRIENDS AND CUSTOMERS:** As the owners of Real Avid, authenticity isn't just a strategy here. It's a guiding philosophy. It arises out of our faith and personal relationships with Jesus Christ. We know that our creativity and success ultimately comes from Him. He cares about each of us and about our customers. We're not perfect, but we are committed to following Him in our personal and business lives.

We look forward to growing our relationship with you and continuing to earn our place.



Revo Brand Group, LLC  
5480 Nathan Lane North, Suite 120  
Minneapolis, MN 55442 USA

RealAvid.com • 800-286-0567

©2018 Revo Brand Group